

MOUNTING

1. Disconnect power supply by the phase fuse, the circuit-breaker or the switch-disconnector combined to the proper circuit.
2. Check if there is no voltage on the connection cables by means of a special measuring equipment.
3. Connect the device cables with the terminals in accordance with the installing diagram.
4. Mount SRM-11 in a junction box.
5. Switch on the power supply from the mains and check if the device operates properly.

CASING DIMENSIONS

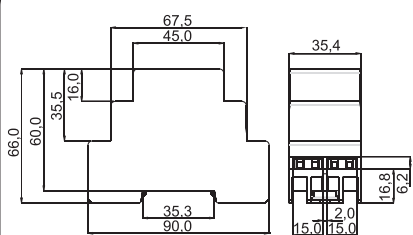

CAUTION

The device is designed for a single-phase installation and must be installed in accordance with standards valid in a particular country. Installation, connection and control should be carried out by a qualified electrician staff, who act in accordance with the instruction manual and the device functions. In case of casing dismantling, the guarantee is lost and an electric shock may occur. Before installation make sure the connection cables are not under voltage. The cruciform head screwdriver 3,5 mm should be used to install the device. Improper transport, storage, and use of the device influence its wrong functioning. It is not advisable to install the device in the following cases: if any device part is missing or the device is damaged or deformed. In case of improper functioning of the device contact the producer.



The symbol means selective collecting of electrical and electronic equipment. It is forbidden to put the used equipment together with other waste.

WARRANTY CARD

There is a 24-month guarantee on the product.

Salesman stamp and signature, date of sale.

INSTALLATION EXAMPLES

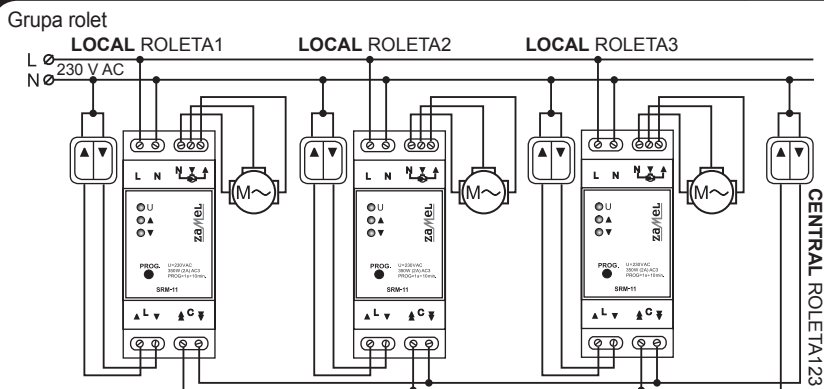

Rozbudowana instalacja roletowa

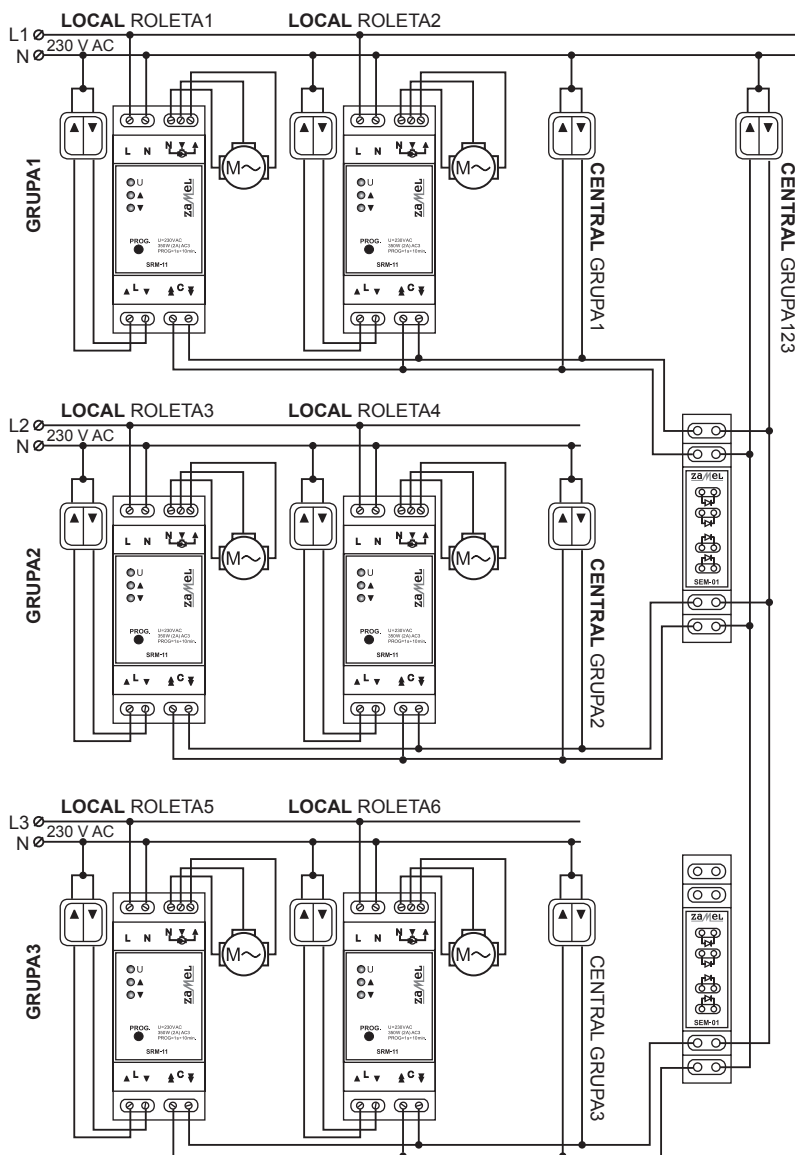

1. ZAMEL Sp. z o. o. assures a 24-month guarantee for the product.
2. The manufacturer's guarantee does not cover any of the following actions:
 - a) mechanical damage during transport, loading / unloading or under other circumstances,
 - b) damage caused by incorrect product mounting or misuse,
 - c) damage caused by unauthorised modifications made by the PURCHASER or any third parties to the product or any other devices required for the product functioning,
 - d) damage caused by Act of God or any other incidents independent of the manufacturer – ZAMEL Sp. z o. o.
 - e) power supply (batteries) to be equipped with a device in the moment of sale (if they appear);
3. The PURCHASER shall lay any claims in writing in the place of purchase or to ZAMEL Sp. z o. o.
4. ZAMEL Sp. z o. o. is liable for processing any claim according to current Polish legislation.
5. ZAMEL Sp. z o. o. shall process the claim at its own discretion: product repair, replacement or money return.1
6. The manufacturer's guarantee is valid in the Republic of Poland.
7. The PURCHASER's statutory rights in any applicable legislation whether against the retailer arising from the purchase contract or otherwise are not affected by this warranty.



ZAMEL Sp. z o.o.

ul. Zielona 27, 43-200 Pszczyna, Poland
tel. +48 (32) 210 46 65, fax +48 (32) 210 80 04
www.zamel.com, e-mail: marketing@zamel.pl



DESCRIPTION

Modular roller blind controller SRM-11 is designed to control window roller blinds or other devices driven by 230 V AC one-phase motors. The control can be carried out in a local or central mode by means of debouncing roller blind push buttons. Single and double roller blind push-buttons can be applied in the local control. In case of central control only double push-buttons can be applied. The device has an additional functionality, it enables to programme two independent comfort (upper / down) settings and maximum roller blind movement time. SRM-11 can operate as an independent controller or it can be connected in a sections. Additionally, the special functionality of central control inputs allows to lock the roller blind in a closed or opened position. The above enables the cooperation with alarm systems and additional devices such as weather station, luminous flux intensity sensor, rain sensor and control timers. N line pulses are the release signals. As a result, in case of an advanced central control installation, particular controllers can be supplied from different phases, but keeping the same N line.

FEATURES

- Designed to wired control of roller blind, sunblind and gate drives,
- control of devices driven by 230 V AC one-phase motors
- a possibility of independent operation or group connection,
- local control realised by means of a single or double roller blind push-button,
- central control realised only by means of double roller blind push-buttons,
- a possibility to block the roller blind position (opened or closed) by means of central inputs,
- a cooperation possibility with the alarm system and additional devices (e.g. rain sensors, control timers, luminous flux intensity sensors),
- N line release only,
- for advanced central control, a possibility to connect controllers to different phases,
- energy-saving devices, designed to continuous operation,
- comfort mode – up and down – roller blind position memory,
- programmable maximum roller blind movement,
- a possibility of cooperation with the exta free system by applying the SRP-03 central line controller.

DANE TECHNICZNE

Supply terminals:	L, N
Nominal supply voltage:	230 VAC
Supply voltage tolerance:	+10 ÷ -15 %
Nominal frequency:	50 / 60 Hz
Nominal power consumption:	0,22 W (stand-by) 0,55 W (during roller blind movement)
Maximum load:	350 W (2 A) - AC3 class
Control signal:	short pulses from N line
Optical signalling of power supply:	green LED
Optical signalling of roller blind movement:	2 x red LED
Roller blind default time:	120 s
Roller blind time programming:	yes – from 1 sec. to 10 min
Comfort positions: yes – up and down	tak – górne i dolne
Comfort mode time range:	from 1 sec. to 10 min
Local control terminals:	L (▲), (▼)
Central control terminals:	C (▲), (▼)
Local control:	single or double roller blind push-buttons
Central control:	double roller blind push-buttons
Motor power supply terminals:	N, (up ▲), (down ▼)
Relay contact parameters:	2NO 10A / 250VAC AC3 2500 VA (voltage contacts)
Number of terminal clamps:	9
Section of connecting cables:	0,2 ÷ 2,50 mm ²
Operation temperature range:	-10 ÷ +55 °C
Operating position:	free
Casing mounting:	TH-35 rail
Casing protection degree:	IP20 (PN-EN 60529)
Protection class:	II
Overvoltage category:	II
Pollution degree:	2
Surge voltage:	1 kV (PN-EN 61000-4-5)
Dimensions:	90 x 35 x 66 mm (double modular)
Weight:	0,090 kg

APPEARANCE

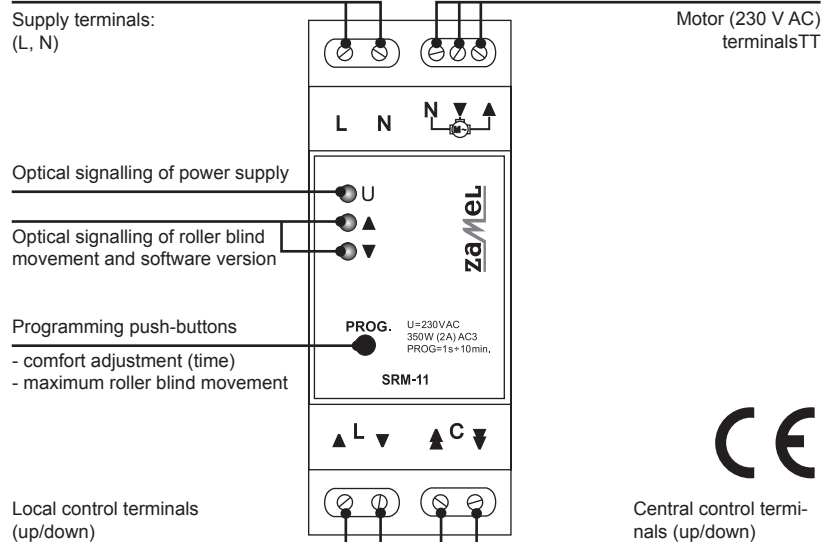

DESCRIPTION

LOCAL CONTROL – DOUBLE ROLLER BLIND PUSH-BUTTON

In this mode, the SRM-11 controller realizes the following functions after pressing shortly (<0,5 sec.) the appropriate push-buttons: opening, closing or stopping the roller blind equipped with 230 V AC single-phase motor. Roller blind movement is consistent with time programmed in a controller. The default time is 120 seconds. Pressing the local control push-button for the first time, causes the roller blind moves in a selected direction, however the subsequent pressing of a push-button stops the roller blind. Its movement is signalled optically by a flashing LED. Pressing longer (>2,5 sec.) the suitable local control push-button causes the activation of programmed comfort settings (up / down).

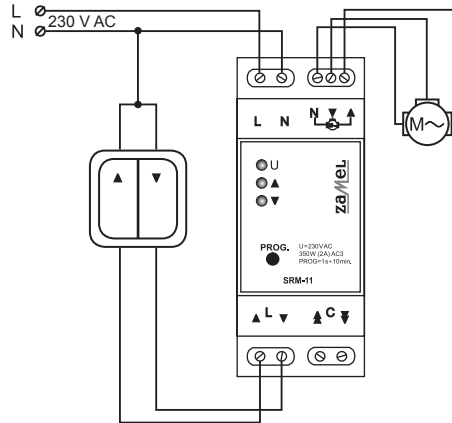

Activation of the upper comfort setting:

In order to activate the upper comfort setting, open completely the roller blind. Next, press longer (>2,5 sec.) the local (L ▼) control push-button. The roller blind starts closing and it will automatically stop in the adjusted upper comfort position.

Activation of the lower comfort setting:

In order to activate the lower comfort setting, close completely the roller blind. Next, press longer (>2,5 sec.) the local (L ▲) control push-button. The roller blind starts opening and it will automatically stop in the adjusted low comfort position.

LOCAL CONTROL – SINGLE PUSH-BUTTON

Local control by means of a single push-button is possible after input connection: L (▲) and L (▼).

In this mode, after pressing shortly (<0,5 sec.) the local control push-button, the SRM-11 controller realizes the following functions: opening, closing or stopping the roller blind equipped with 230 V AC single-phase motor. Roller blind movement is consistent with time programmed in a controller. The default time is 120 seconds. The roller blind movement operates according to a sequence: open – stop - close. Roller blind movement is signalled optically by a switched on LED. Longer pressing (>2,5 sec.) the local control push-button causes the activation of programmed comfort settings.

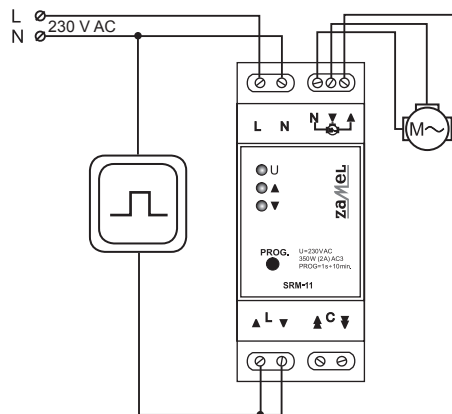

Activation of the upper comfort setting:

In order to activate the upper comfort setting, open completely the roller blind. Next, press longer (>2,5 sec.) the local control push-button. The roller blind starts closing and it will automatically stop in the adjusted upper comfort position.

Activation of the lower comfort setting:

In order to activate the lower comfort setting, close completely the roller blind. Next, press longer (>2,5 sec.) the local control push-button. The roller blind starts opening and it will automatically stop in the adjusted low comfort position.

Caution:

Comfort setting times (upper /down) are the same in case of single and double push-button control. The programmed roller blind movement time must be longer than times programmed for the comfort mode. After local control mode change from a single to a double push-button, it is necessary to disconnect power supply of the device and connect it again (controller restart).

OPERATION

LOCAL CONTROL – DOUBLE ROLLER BLIND PUSH-BUTTON

In this mode, the SRM-11 controller realizes the following functions after pressing shortly (<0,5 sec.) the appropriate push-buttons: opening, closing or stopping the roller blind equipped with 230 V AC single-phase motor. Roller blind movement is consistent with time programmed in a controller. The default time is 120 seconds. Pressing the local control push-button for the first time, causes the roller blind moves in a selected direction, however the subsequent pressing of a push-button stops the roller blind. Its movement is signalled optically by a flashing LED. Pressing longer (>2,5 sec.) the suitable local control push-button causes the activation of programmed comfort settings (up / down).

Locking mode of central control inputs

Central control inputs allow to lock a roller blind in the closed or opened position. To carry it out, it is necessary to give a constant L line signal to the appropriate (\blacktriangle , \blacktriangledown) central input. The above can be realised by means of the control panel, luminous flux intensity sensor, rain sensor, or control timer. In the locking mode all remaining inputs are inactive. The central control inputs are designed to a long-lasting release.

Exemplary application:

Astronomical time programmer ZCM-31 realizes the function of the central closing of roller blind system at dusk. Local / central control is possible only at dawn when the timer contacts 11-14 are open.

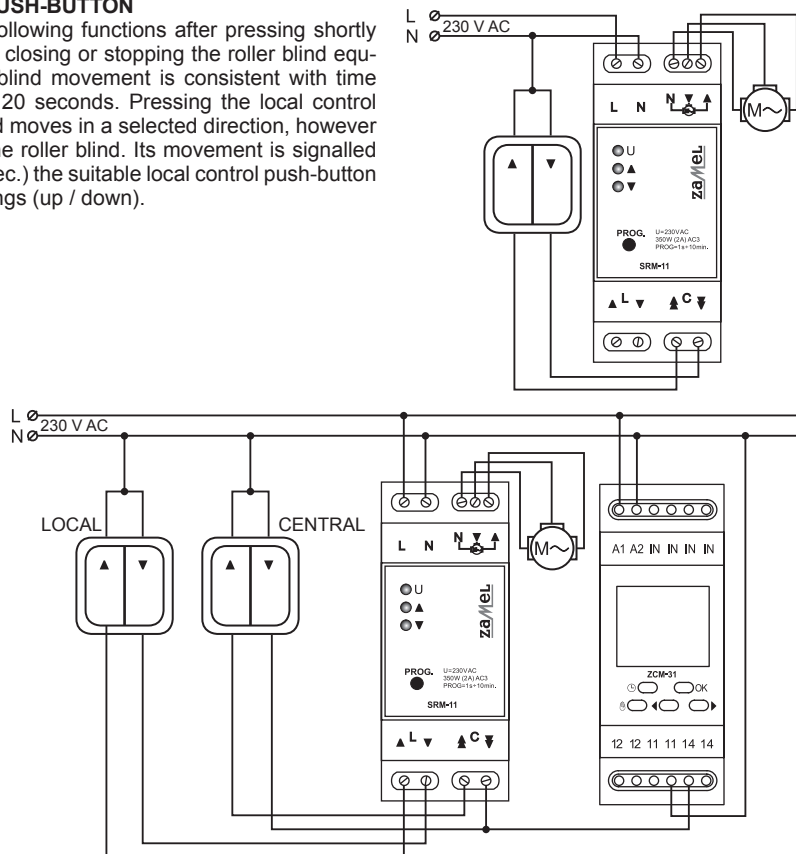

TIME PROGRAMMING

Programming roller blind motion time

Roller blind movement time can be programmed in the range of 1 second to 10 minutes. The same time measure is for the upward and downward roller blind movement. Its default time is 120 sec. Due to mechanical issues, the roller blind opening is longer than its closing. In this case it is recommended to start time programming of a roller blind from the bottom position (a completely closed roller blind).

In order to programme the roller blind movement time, the following steps are required:

1. Close the roller blind completely.
2. Press the PROG push-button placed on the casing of the SRM-11 controller.
3. The roller blind starts opening and, simultaneously, time is measured. Both steps are signalled optically by flashing LEDs, which indicate the roller blind movement.
4. If the roller blind is in the upper position, press any push-button (local/central control). The roller blind stops and the measured time is saved in the SRM-11 memory. This time is remembered even after power supply failure.

Comfort (time) setting programming

Comfort setting time can be programmed in the range of 1 second to 10 minutes. The upper comfort time is differently programmed than the bottom time comfort.

UPPER COMFORT SETTINGS

In order to programme the upper comfort (time) setting, the following steps must be carried out:

1. Open the roller blind completely.
2. Press the PROG push-button placed on the casing of the SRM-11 controller.
3. The roller blind starts closing and, simultaneously, time is measured. Both steps are signalled optically by flashing LEDs, which indicate the roller blind movement.
4. If the roller blind is in the upper position, press any push-button (control/central). The roller blind stops and the measured time is saved in the SRM-11 memory. This time is remembered even after power supply failure.

LOWER COMFORT SETTINGS

In order to programme the lower comfort (time) setting, the following steps must be carried out:

Czasy komfortowe są pamiętane po zaniku napięcia zasilającego.